

When developing new drugs, shortening time-to-market and reducing waste of expensive API's and overall development costs provide a distinct competitive advantage. Hence, quick and early assessment of new API/excipient formulations is critical. The Thermo Scientific Pharma *mini* HME allows users to identify the right drug candidates for hot melt extrusion by compounding as little as 3 grams of material.

Thermo Scientific Pharma *mini* HME

Conical Micro-Compounder for Hot Melt Extrusion built to GMP standards

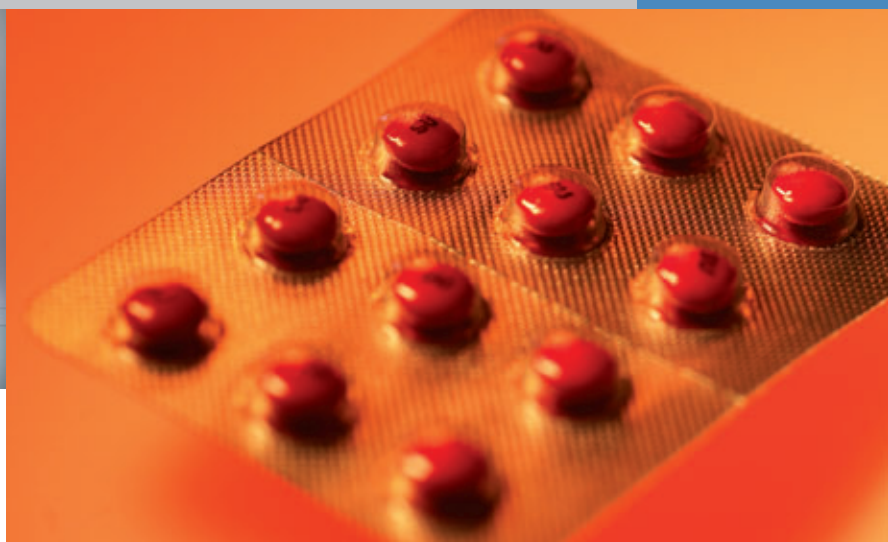

Materials:

- Pharmaceutical ingredients (API's)
- Excipients
- Medical polymers
- Drug delivery systems
- Soft gels

Applications:

- Hot melt extrusion
- Medical devices
- Implants
- Controlled drug release
- Handling and processing of highly potent API's in a glovebox

The challenge

Hot melt extrusion and continuous processing can lead to speedier formulation development and cost efficient production. But in development of new drugs, users are still faced with several challenges. Due to very expensive and hence limited quantities of API, finding the right API/excipient formulation and testing if this formulation is the right candidate for hot melt extrusion can be difficult. In this phase, the health effects of a new API are often not clear. Therefore it can be necessary to run such trials in a laminar flow or glovebox. On the other hand, new special implants designed for controlled drug release are produced in such small dimensions that a delivery rate of only a few grams per hour is required to establish a micro production line.

The solution

With the Pharma *mini* HME, we offer a micro twin-screw compounder which requires as little as 3 grams of total material to identify the right drug candidates for hot melt extrusion. The compounder with conical co- or counter-rotating screws is designed to minimize waste and reduce downtime necessary for cleaning.

The product contact parts can be easily removed and cleaned using a washing machine and an autoclave. But even washing the product contact parts by hand is simple due to rounded edges and minimized screw threads and crevices. To reduce the risk of cross-contamination and cleaning downtime to a minimum, additional sets of product contact parts are available.

All parts are designed and manufactured to allow easy handling as well as quick assembling and disassembling, even with gloves in containment solutions such as a laminar flow box or a glovebox. This containment solution is also supported by the very small footprint of the Pharma *mini* HME and the separate touch screen control which offers the same look and feel as the larger Thermo Scientific Pharma twin-screw extruders. The IP 54 rating and the fanless design allow the operator to spray-wash the Pharma *mini* HME to bind powdery excipients and APIs.

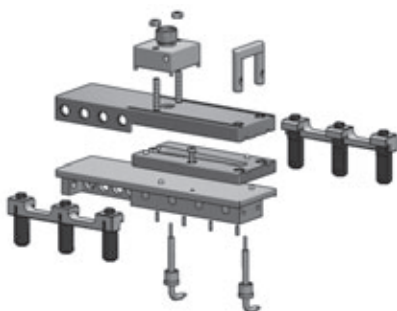

The conical screw design offers the advantage of reducing total volume and extra pressure build up at the screw tips to extrude a uniform material with constant output rates. In addition, the conical design offers the best mixing capability on such a small scale and allows the Pharma *mini* HME to operate without the use of expensive and sensitive feeding devices.

In combination with the integrated feed port cooling and an optional continuous force feeder, the Pharma *mini* HME can be used as continuous small scale compounder to prepare samples for clinical trials or for micro production of medical devices and implants as drug delivery systems. The shape of the extruded material can be controlled by adding various die sections.

With its design and technical features the Pharma *mini* HME fits seamlessly to the Thermo Scientific pharma product portfolio and adds another tool to the workflow solution "from lab to line".

Ancillary equipment

Several feeding solutions, from a manual piston feeder for small quantities of material as well as a force feeder for continuous feeding, to support the continuous micro production are available.

The modular design of the Pharma *mini* HME allows an easy exchange of the product contact parts. Spare barrel components and screws are available. A batch conversion kit which includes a barrel with backflow channel and a manual bypass valve is also available allowing the Pharma *mini* HME to be converted from a continuous compounder to a small batch mixer with adjustable residence time. This enables the unit to evaluate the mixing behavior and thermal stability of the drug/excipient formulation.

With the Thermo Scientific HAAKE MiniJet micro injection molding machine, the Pharma *mini* HME offers a complementary workflow solution to create a test specimen for formulation development and to characterize melt extrudate solid dosage forms.

The Thermo Scientific Pharma *mini* HME is designed and manufactured according to GMP requirements incorporating a full set of validation documentation.

To complete our comprehensive solutions, our international team of material characterization and pharma experts provide proven answers for small sample compounding.



Features and benefits

- Requires only 3 g (4 ml) of material for compounding
- Small footprint, fanless design with separate, touch-screen control for operation in fume cabinet or glovebox applications
- Removable and exchangeable product contact parts for quick and easy cleaning
- IP 54 for protection against dust and water allows the Pharma *mini* HME to be spray-washed
- Useable as small-scale production unit for throughputs of 100 g/h
- Touch screen control with user levels and password protection
- Data logging software as option to record temperatures, torque, and screw speed
- Optional batch conversion kit to use the Pharma *mini* HME as small batch mixer
- Complementary workflow solution when coupled with the Thermo Scientific HAAKE MiniJet injection molder

Technical Specifications

Motor power	400 W
Speed range	10...360 min ⁻¹
Max. torque	5 Nm / shaft
Power supply	230 V ± 10 %, 50/60 Hz 115 V ± 10 %, 60 Hz
Design	Conical co-/counter rotating
Temperature	Max. 280 °C
Heating time (22° – 170°C)	< 10 Minutes
Volume	3 g (4 ml)
Screws	Co- or counter rotating, pharma grade stainless steel 1.4112 (440 B)
Barrel	High performance / pharma grade stainless steel M340

© 2011/09 Thermo Fisher Scientific Inc. - All rights reserved - 623-3089 - This document is for informational purposes only and is subject to change without notice. Specifications, terms and pricing are subject to change. Not all products are available in all countries. Please consult your local sales representative for details. Copyrights in and to the blister image are owned by a third party and licensed for limited use only to Thermo Fisher Scientific by istockphoto.

Process Instruments

Benelux

Tel. +31 (0) 76 579 55 55
info.mc.nl@thermofisher.com

China

Tel. +86 (21) 68 65 45 88
info.mc.china@thermofisher.com

France

Tel. +33 (0) 1 60 92 48 00
info.mc.fr@thermofisher.com

India

Tel. +91 (20) 6626 7000
info.mc.in@thermofisher.com

Japan

Tel. +81 (45) 453-9167
info.mc.jp@thermofisher.com

United Kingdom

Tel: +44 (0) 1606 548 100
info.mc.uk@thermofisher.com

USA

Tel. 603 436 9444
info.mc.us@thermofisher.com

International/Germany

Dieselstr. 4
76227 Karlsruhe
Tel. +49 (0) 721 4 09 44 44
info.mc.de@thermofisher.com

www.thermoscientific.com/mc

Thermo
SCIENTIFIC